

Torsion in Shafts problem

Friday, 7 March, 2025 07:16 AM

- 5-17. The rod has a diameter of 1 in. and a weight of 10 lb/ft. Determine the maximum torsional stress in the rod at a section located at A due to the rod's weight.

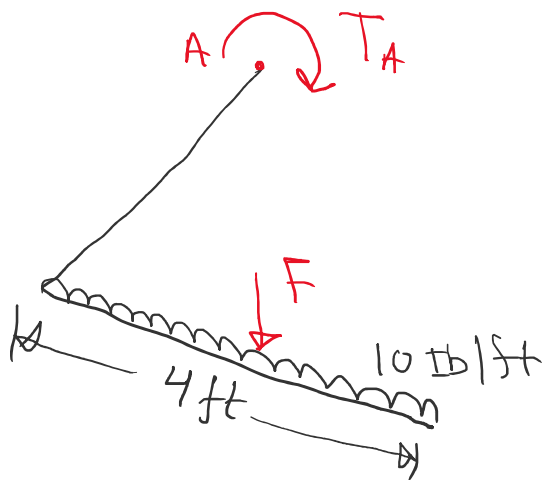
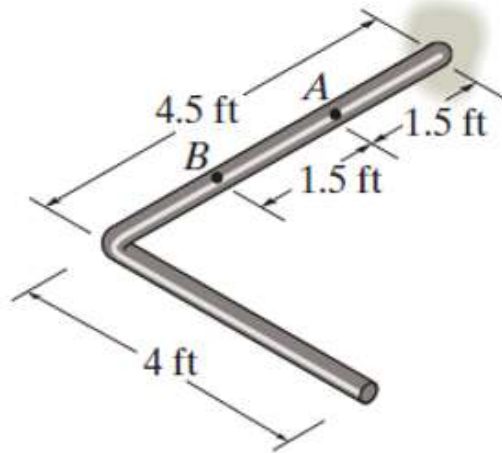

$$F = 10 \text{ lb/ft} \times 4 \text{ ft} = 40 \text{ lb}$$

$$T_A = F \times \frac{4 \text{ ft}}{2} = 40 \times 2 = 80 \text{ lb-ft}$$

$$\Rightarrow T_A = 80 \times 12 = 960 \text{ lb-in}$$

To find: τ_A

We know:

$$\frac{\tau_{max}}{R} = \frac{T_{max}}{J} \quad [\text{Torsion equation}]$$

$$\Rightarrow \frac{\tau_{max,A}}{R_A} = \frac{T_{max,A}}{J_A}$$

$$\Rightarrow \frac{\tau_{max,A}}{0.5} = \frac{960 \text{ lb. in}}{\frac{\pi}{2} (0.5)^4}$$

$$\Rightarrow \tau_{max,A} = \frac{960}{\frac{\pi}{2} 0.5^3} = 4889.24 \text{ psi}$$

$$= 4.89 \text{ ksi}$$

This problem was solved by Civil Thinking (<https://civilthinking.com>)

If you need solutions for **Strength of Materials** or any other **Civil Engineering** subject, contact us at:

solutions@civilthinking.com

You can also WhatsApp us at: +916005765266 to get problem solutions.

Or submit your problem directly here:

 <https://civilthinking.com/getproblemsolutions>

Other Subjects We Cover:

- Structural Analysis
- Fluid Mechanics
- Geotechnical Engineering
- Transportation Engineering
- Construction Management
- Finite Element Analysis (FEA)
- Engineering Software (ANSYS, ETABS, MATLAB, Revit)

Let us help you solve your engineering challenges! 